

Company History

1937

Arthur and Grace Redner founded General Filters, Inc. (GFI) in 1937. It was in Detroit Michigan where Arthur Redner laid the foundation and perfected the application of vehicle lube oil filtration.

1940's

During World War II, Arthur Redner was awarded a government contract for an engine driven portable filter device for military aircraft ground support. The implementation of wool filter elements to clean lubricating oils was applied. It was here where the Trademark General Red Top and Black Can Fuel Oil Filter had its beginning in the residential oil heating market.

1949

GFI expanded operations to include Canada by founding Canadian General Filters, Ltd (CGF) in Scarborough, Ontario.

1950's

GFI diversified into other markets by introducing whole-house humidification to the home heating industry. GFI offered six flow-through pad type design models and featured two plate type design models as well. In 1955, Arthur Redner retired. Grace Redner assumed the presidency.

1969

Grace Redner presides as Chairman of the Board while sons Roland and Robert P. Redner manage the company into the 1980's each serving as president.

1980's

The General Humidifier was known for its performance, quality, and dependability. So it was time to apply those same standards with the introduction of the General high efficiency micro-fiber media air cleaner.

1990's

A unique whole-house activated charcoal base air purifier was introduced to reduce the affects of the growing problem of indoor air pollution. GFI rattles the saber with its early contribution and commitment to improve indoor air quality (IAQ). Robert P. Render presides as Board Chairman.

The 21st Century

The third generation of the Render Family leads General Filters, Inc. with the same commitment to manufacture dependable, high performance, premium indoor air quality products, fuel oil filters and accessories.

John A. Redner	President
Carl Redner	Vice President of Engineering
Robert R. Redner	Vice President of Finance and Administration

Today, General Filters, Inc. continues to provide high quality products throughout North America by way of strong distribution partnerships. The strength of market presence is buoyed by recognizable brands as GeneralAire, General, Unifilter, GarBer and other private label branding agreements.

The air we breathe indoors is 2 to 5 times more polluted than the air we breathe outdoors!

The average person spends 90% of a 24 hour day indoors. Our health could be at risk!

Improper humidity levels, dangerous gas molecules, mold spores, germs, and microscopic particulates all affect our long term health and comfort. GeneralAire has the answer to significantly reduce harmful airborne

contaminants in the air we breathe. Install a GeneralAire Humidifier, UVC Photocatalytic Air Purifier, HEPA Air Cleaner, and a MAC Series Air Cleaner for a complete indoor air quality system.

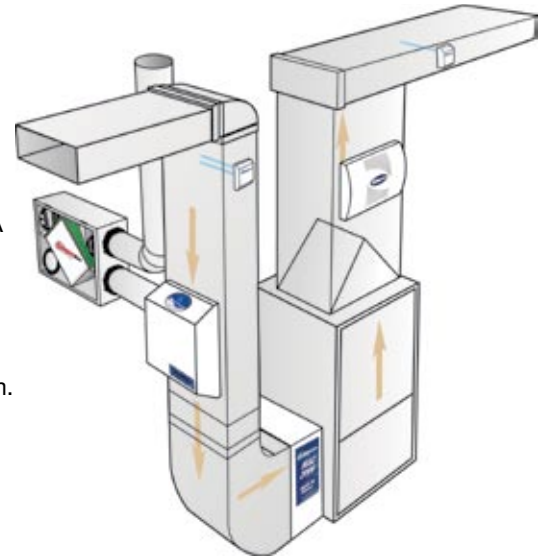

The Center for Disease Control and Prevention categorizes indoor air pollution into three phases: Particulates, Gases, and Germs.

35% of allergic reactions are caused by the levels of particulates in the air we breathe indoors. 34% of allergic reactions are caused by levels of microorganisms (germs) in the air we breathe indoors. 31% of allergic reactions are caused by the amount of chemical gases found present in the air we breathe in our homes and at work.

